

Typical for butt joints

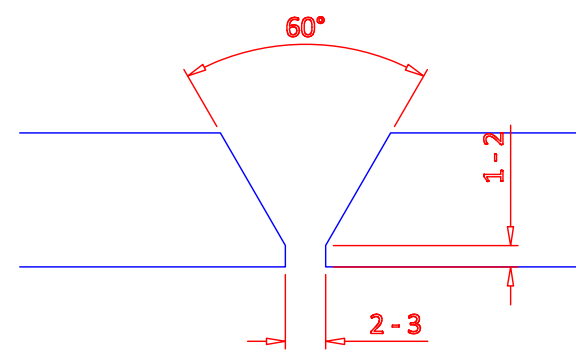

Typical for T-joints

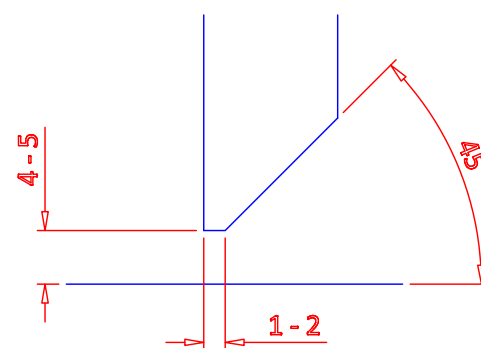

When not indicated, the throat thickness must be chosen by the ANB between 0,5 and 0,7 times the thinnest wall thickness of the joint.

Item N°	Material	Drawing N°	Quantity
1	1	ITW-001	1
2	1	ITW-002	1
3	1	ITW-003	1
4	1	ITW-001	1
5	1	ITW-002	1
6	1	ITW-003	1
7	1	ITW-001	1
8	1	ITW-002	1
9	1	ITW-003	1
Drawn	25/10/2010	ITW test object-000 assembly 45°	
Check			
Rev.	04		
Appr.		Drawing N° ITW - 000	